

Foundations of Advanced Mathematics
AS Pure Mathematics Bridging Test 2

Questions

- 1 Anne has a number of identical rectangular boxes. She measures the length to be 8 cm, the width 5 cm and the height 4 cm, all correct to the nearest cm. Three of the following statements are true and **one** is false. Which one is **false**?
- A The greatest possible length when 10 boxes are placed end to end is 85 cm.
- B The width when 2 boxes are placed side by side is no more than 11 cm.
- C The height when 3 boxes are stacked is at least 10.5 cm.
- D The greatest possible volume of a box is 160.5 cm^3 .
- 2 Three of the following statements are true and **one** is false. Which one is **false**?
- A 12 inches is about 30 centimetres.
- B 5 tonnes is 5000 kilograms.
- C 1 litre is about 1.8 pints.
- D 25 kilometres is about 40 miles.
- 3 Three of the following statements are true and **one** is false. Which one is **false**?
- A $-2 \times -3 = -6$
- B $(-2) - (-3) = 1$
- C $\frac{3+4 \times 13}{17-3 \times 2} = 5$
- D $20 - 2 \times 3 = 14$
- 4 In this question, $a = 2$, $b = 3$, $c = -1$. Three of the following statements are true and **one** is false. Which one is **false**?
- A $ab^2 = 18$
- B $abc^3 = -6$
- C $ab + bc + ca = 1$
- D $\frac{a+2b}{4-2c} = 4$

- 5 A piece of insulation fits round a pipe. It has the shape of a cylinder with a smaller cylinder cut out of it, as shown in the diagram. The inside radius is 2 cm and the outside radius is 7 cm. The length is 9 cm.

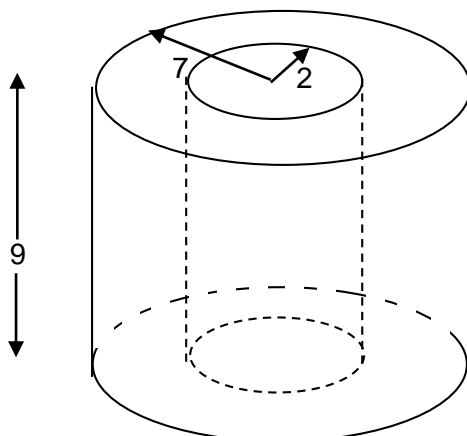

Which **one** of the following is the **correct** volume of the piece of insulation, correct to 3 significant figures?

- A 1270 cm³
B 707 cm³
C 6360 cm³
D 1340 cm³
- 6 Michael and Madison are rearranging equations.

Michael has rearranged $v^2 = u^2 + 2as$ to give $a = \frac{(v-u)(v+u)}{2s}$.

Madison has rearranged $s = \frac{1}{2}(u+v)t$ to give $v = u + \frac{2s}{t}$.

Which **one** of the following statements is **true**?

- A Both Michael and Madison are incorrect.
B Both Michael and Madison are correct.
C Michael is correct and Madison is incorrect.
D Michael is incorrect and Madison is correct.

7 This question concerns the graph of the function $y = x^3 - 6x^2 + 9x + 2$.

The following table gives values of y for some integer values of x .

x	-1	0	1	2	3	4	5
x^3	-1	0		8			
$-6x^2$	-6	0		-24			
$9x$	-9	0		18			
2	2	2		2			
y	-14	2		4			

Part of the graph is shown on the grid below.

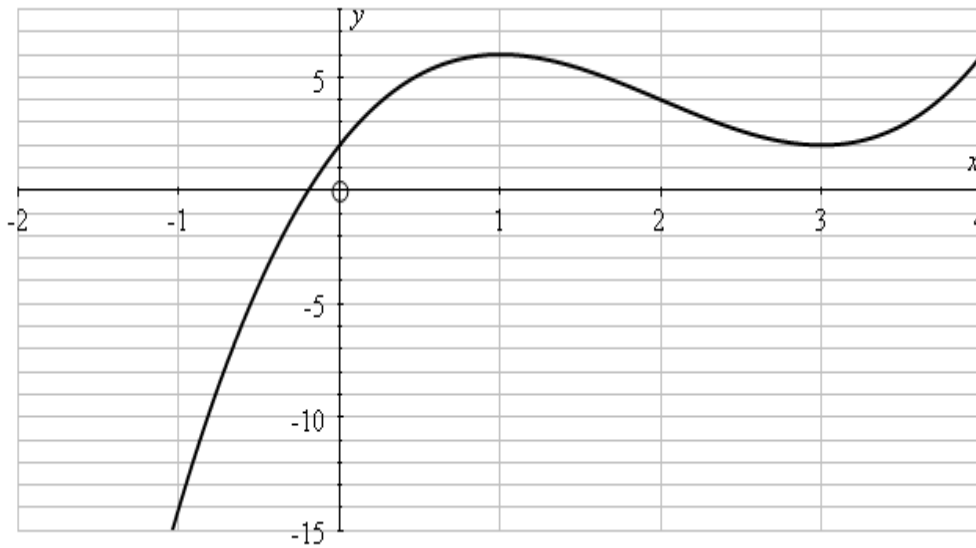

In order to complete this question you are advised to complete the table above and complete the graph on the grid using your values from the table.

Three of the following statements are true and **one** is false. Which one is **false**?

- A The value of y when $x = 3$ is 2.
- B Between $x = -1$ and $x = 3$ the maximum value of y occurs when $x = 1$.
- C The gradient of the curve when $x = 2$ is approximately 3.
- D The area under the curve between the x -axis, the lines $x = 0$, $x = 2$ and the curve is approximately 10 square units.

- 8 A road tunnel has a semicircular cross-section, as shown in the diagram. The road surface is on the diameter AB of the semicircle which has length 10 metres. The road surface is symmetrically placed in the tunnel and of width 8 metres, leaving 1 metre on either side.

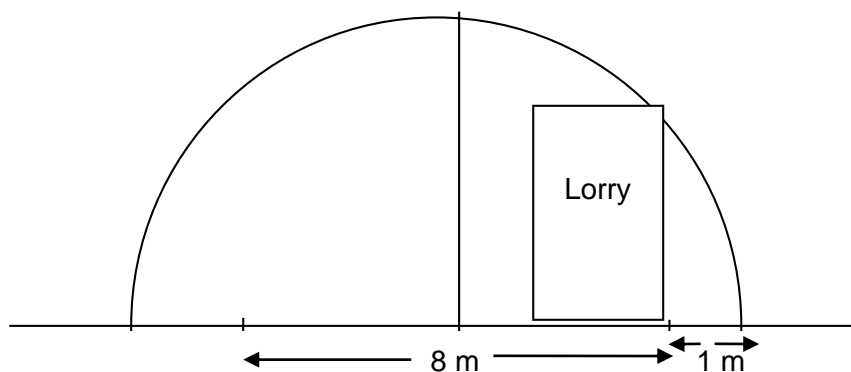

Which **one** of the following is the maximum height of a lorry that drives on the edge of the road?

- A 2 m B 3 m C 4 m D 5 m
- 9 The graph below shows the conversion of pounds, £, to euros, €, one day last year.

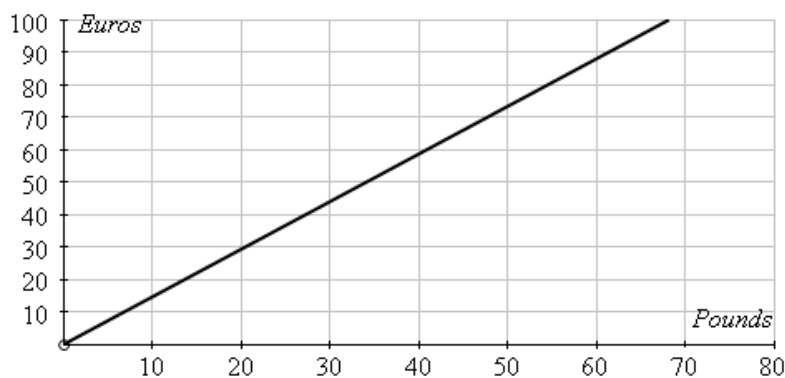

Three of the following statements are true and **one** is false. Which one is **false**?

- A £40 was equivalent to nearly €60.
- B €40 was approximately equivalent to £27.
- C One euro was worth approximately 68p.
- D On another occasion I paid £70 for €100. The conversion graph for this exchange rate has a greater gradient than that drawn above.
- 10 Which **one** of the following gives the solution, correct to 1 decimal place, of the equation $x^2 + 3x = 1$?

- A** $x = 0.3$ and $x = -3.3$
- B** $x = -0.3$ and $x = 3.3$
- C** $x = -0.4$ and $x = 2.6$
- D** $x = 0.4$ and $x = -2.6$